

Amazing Water

Purifying
Moving
Designing
Vitalising
Lighting
Installation



Mixers and aerators

Programme and technical specifications 2024

WATER VITALISING



Fish death due to oxygen deficiency.



Suffocation caused by duckweed.



Odour nuisance caused by oxygen deficiency.



Water movement and aeration is crucial for improving water quality and is indispensable in every water culture. Oxygen-rich water contributes to the biodegradation of organic substances in the water.

AUGA builds aerators and mixers for optimizing and maintaining water quality in a diversity of waters, where the risk of algae formation, odour nuisance, oxygen deficiency, fish mortality and stratification significantly reduces.



Temperature reduction.



Cyanobacteria.



Keep water free of ice.



PUBLIC WATER AND RECREATIONAL LAKES

Stagnant - and often shallow - water could be a source of nuisance in rising temperatures. In addition to fish deaths due to oxygen deficiency, the water starts to smell, becomes infested with mosquitoes and suffers from excessive algae growth due to the water heating up.

During warm periods, water in particularly cities, parks, campsites and other recreational sites has to regularly deal with these issues and it could even result in a swimming ban.

Another problem occurs with excessive rainfall. Rainwater is still frequently drained via the sewer system. During downpours this system is often overloaded and emergency overflows take effect, which often results in water arriving in public ponds. The discharged sewage water leads to acute oxygen deficiency causing mass fish deaths.



INDUSTRY

A lot of water is reused in industry such as rinsing water for the fruit and vegetable processing industry. The quality of rinsing water is significantly increased if it is mixed and aerated, and solid substances such as sand are separated more efficiently from the rinsing water. Mixing and aeration also reduces odours.

STORAGE WATER IN GREENHOUSES

Storage water in greenhouses is used for sprinkling/drip irrigation. Stagnant water causes algae growth and can result in disruptions to micro-sprinkler systems. Circulating and aerating water combats algae formation and the storage water stays fresh.





FISHING WATERS

Declining fish catches and fish deaths: two major problems in fishing ponds. When fishing clubs periodically increase the number of fish in the ponds they manage, the biomass can become greater than the pond's carrying capacity. As time passes the fish stock will return to the carrying capacity, which means that sooner or later the condition of the added fish will deteriorate or they could even die.

Mixing the water layers and adding oxygen increases the carrying capacity, with the aim of maintaining the quantity of fish in a pond at a higher level for a long time.



MOATS

Moats mainly play an aesthetic role around castles and country homes. When maintaining a moat, stagnant and foul-smelling water, fluctuating water levels, duckweed entirely covering the surface and sediment can be real problems.

Adding circulation to the water and mixing water layers significantly improves its quality, contributes to soil amelioration, keeps duckweed in check and oxygenates the lower water levels.

Type	Flow	MegaFlow	AirFlow	Mega AirFlow	Megaflow combi	S-Flow	V-Flow	Airtec	AirTec Pro
Oxygenation			●	●	●	●	●		
Circulation	●	●	●	●	●				
Anti-layer formation	●	●	●	●	●				
Flotation			●	●					
Soil amelioration			●	●	●				
Temperature reduction	●	●				●			
Aeration			●	●	●	●	●	●	●
Degassing			●	●		●			
Keeping water free of ice	●	●	●	●	●			●	●
Decorative fountain							●		
Noise level	0	0	00	00	00	000	000	0	0

Flow mixers in floating and fixed arrangement

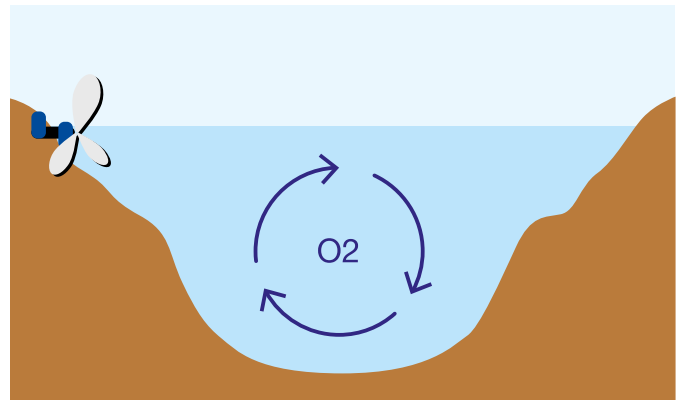
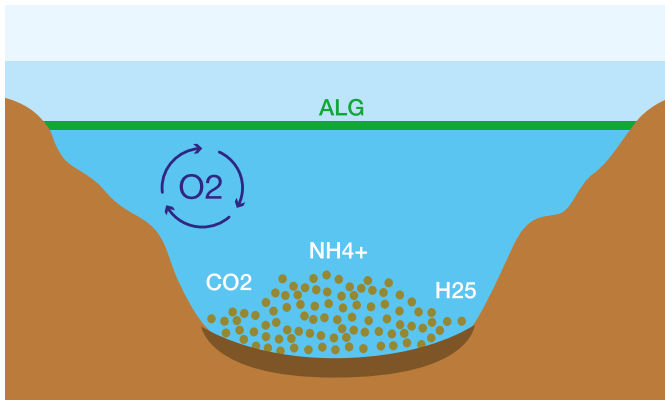

Mixers for ponds, moats and fish ponds

To create a healthy aquatic ecosystem, achieving a homogeneous water zone composition is crucial. It regulates the concentration of nutrients, oxygen and temperature, which is usually blocked (stratification) in the upper water layer, depending on the shape of the pond or basin.

Good circulation helps prevent the accumulation of dirt and the formation of gas due to the organic breakdown of bottom debris and is cost effective because less maintenance is required.

Mixers create water currents that add oxygen and are rich in nutrients, allowing fish and other aquatic life to thrive.

Circulation is also an excellent solution for limiting algae blooms. The adjustable position of the motor facilitates optimum placement in the water.

Mixers for waste water and recycling water

It goes without saying that water is a valuable resource. The need to reuse wastewater that is used in a production process that uses a lot of water is undeniable. The control of costs to obtain the desired water quality for re-use are equally significant.

The mixers and aerators are stand-alone units that can be fixed or floating, without the need for additional structural facilities. Because the equipment runs just below the surface of the water, its efficiency is high.

MegaFlow mixers

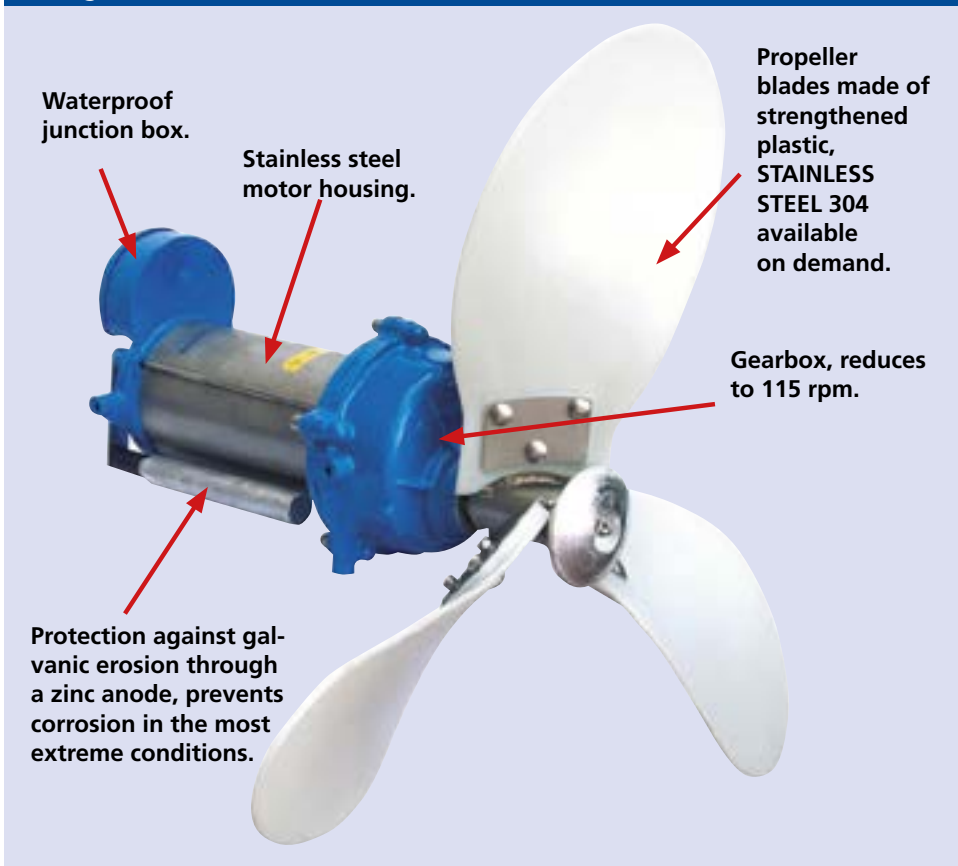

Technology

The specially designed motors are the powerhouse behind any installation and are built for continuous use under highly variable conditions with a wide variety of applications.

- Suitable for freshwater and saltwater.
- Oil-immersed double mechanical seal (oil biodegradable).
- Bronze or stainless-steel motor housing.
- Motor cables can be supplied in any length.
- 230 V connection voltage 1 Ph (up to 1.5 kW), 400 V 3 Ph, other voltages available on request.
- Tailor-made systems available.



Flow mixers

Flow propeller mixers provide circulation and mix the water layers in stagnant water in moats, ponds, lakes and storage basins.

Type	Configuration	P2 motor kW	Voltage V/Hz	Cable m	L x W x H mm	Art. no.
Flow 37 F	Floating	0.37	230/50	20	980 x 980 x 770	103101
Flow 37 S	Fixed	0.37	230/50	20	556 x 590 x 530	103100
Flow 75 F	Floating	0.75	230/50	20	980 x 980 x 770	103104
Flow 75 S	Fixed	0.75	230/50	20	556 x 590 x 530	103102
Flow M-150 F	Floating	1.50	230/50	20	980 x 980 x 770	103106
Flow M-150 S	Fixed	1.50	230/50	20	556 x 590 x 530	103105

Flow 75 S - Fixed arrangement



Flow 75 F - Floating set-up



Applications

- Circulation.
- Anti-layer formation.
- Temperature reduction.
- Keeps water free of ice.

Technical information

- Variable flow angle.
- Base plate with counterweight.
- Protective cage around the propeller.
- Inc. anchoring eyelets.
- Also available in 400 V 3 Ph.
- Motor cable can be supplied in any length.
- 'F' model with plastic float.
- Types 37 and 75: 1400 tpm
- Type 150: 2800 tpm

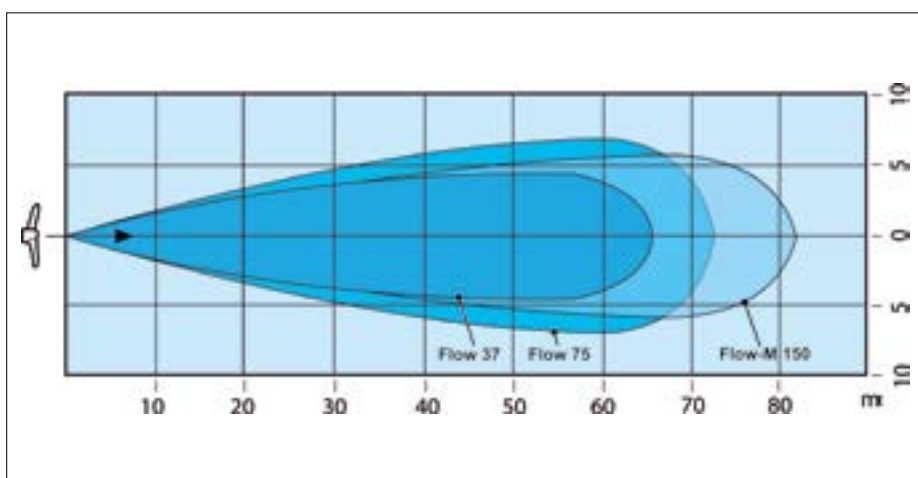

Work area

- Control pump, see page 22.
- Anchoring set, see page 23.

MegaFlow mixers

MegaFlow mixers circulate very large quantities of water with low energy consumption, suitable for large-scale water projects.

Type	Configuration	P2 motor kW	Voltage V/Hz	Cable m	L x W x H mm	Art. no.
MegaFlow 75 F	Floating	0.75	230/50	20	1958 x 1860 x 1306	103114
MegaFlow 75 S	Fixed	0.75	230/50	20	1958 x 1006 x 1306	103112
MegaFlow 150 F	Floating	1.50	230/50	20	1958 x 1860 x 1306	103116
MegaFlow 150 S	Fixed	1.50	230/50	20	1958 x 1006 x 1306	103115

MegaFlow 150 F - Floating set-up



MegaFlow for wall installation



Applications

- Circulation.
- Anti-layer formation.
- Temperature reduction.
- Keeps water free of ice.

Technical information

- Variable flow angle.
- Low-speed motor:
Type 75: 1400/123 rpm
Type 150: 1400/112 rpm
- Also available in 400 V.
- Motor cable can be supplied in the required length.
- Fixed and floating configuration.
- Alternative constructions possible.
- 'F' model with plastic float.

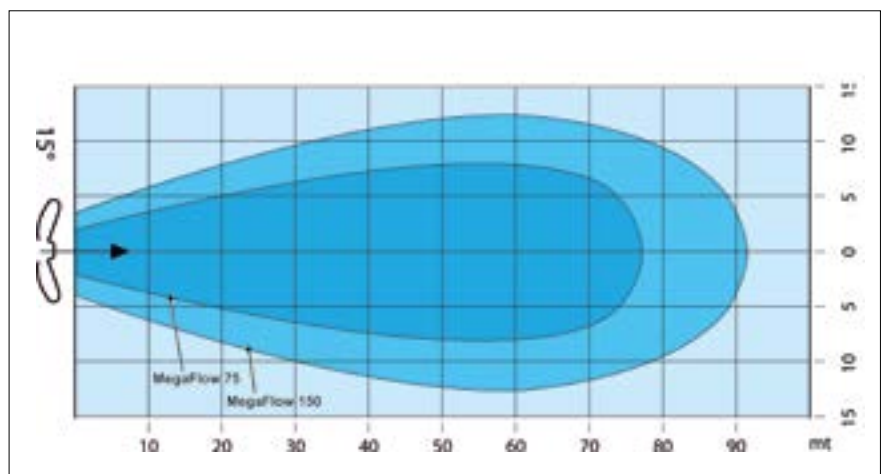

Work area

- Control pump, see page 22.
- Anchoring set, see page 23.

AirFlow aerators in floating and fixed installation

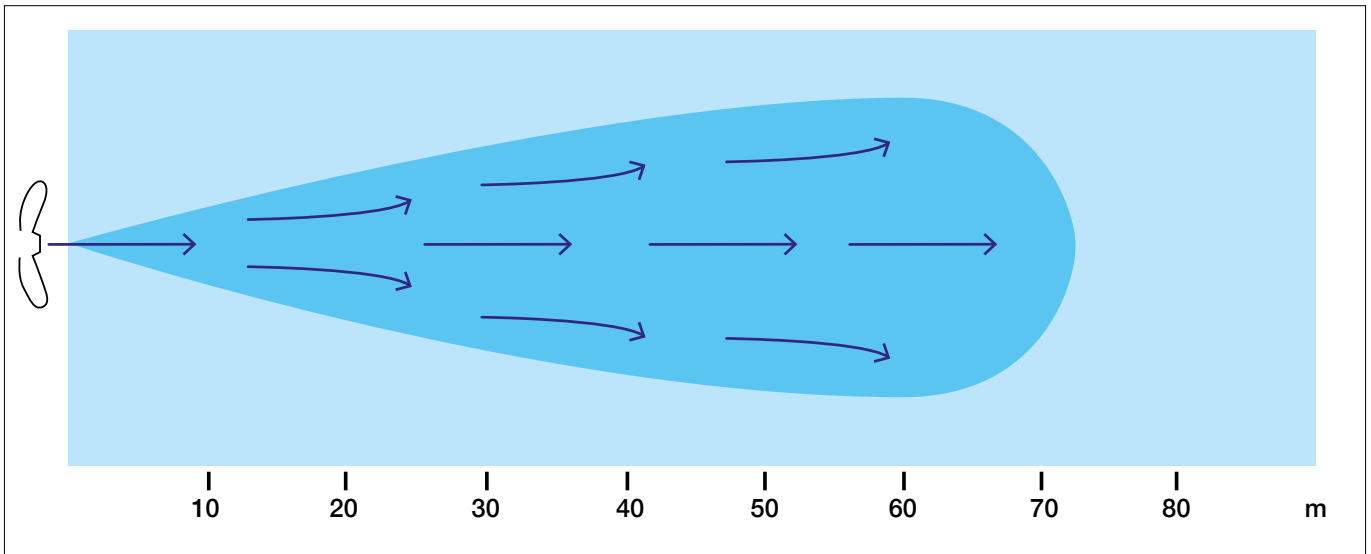

Moving and aerating

Underwater aeration is achieved through systems that inject air at certain depths and dissolve air/oxygen in micro bubbles. The large contact surface of these bubbles enables them to transport oxygen throughout the entire water column.

The horizontal movement increases the contact time between air and water, prevents loss of oxygen and increases the oxygen transfer rate.

On top of that, horizontal movement also prevents bottom erosion when applied in bodies of water with a natural bottom. The underwater aerator ensures its entire working range is richly oxygenated, mixed and circulated.

AirFlow aerators

Protection against galvanic erosion through a zinc anode, prevents corrosion in the most extreme conditions.

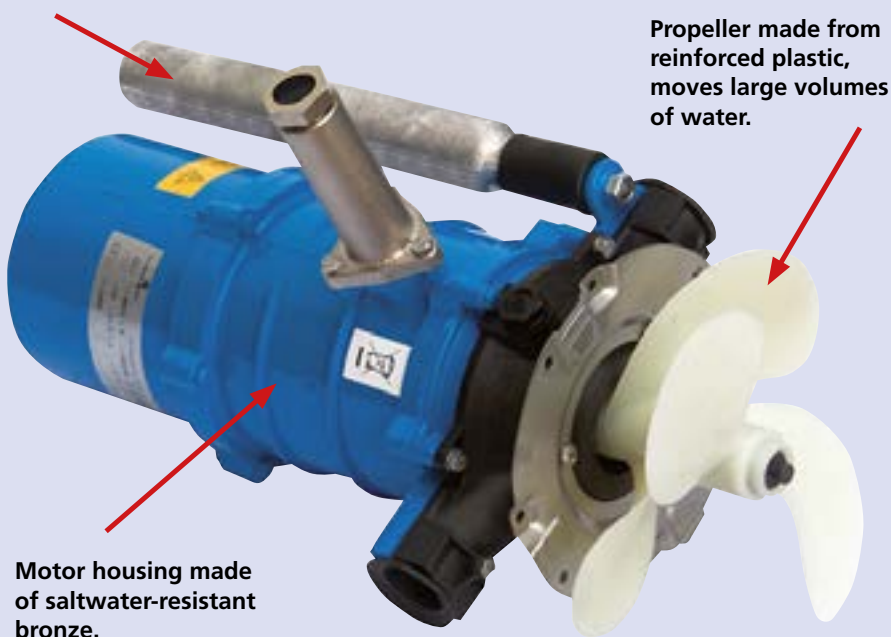

Technology

The specially designed motors are the powerhouse behind any installation and are built for continuous use under highly variable conditions with a wide variety of applications.

- Suitable for freshwater and saltwater.
- Oil-immersed double mechanical seal (oil biodegradable).
- Bronze or stainless-steel motor housing.
- Motor cables can be supplied in any length.
- 230 V connection voltage 1 Ph (up to 1.5 kW), 400 V 3 Ph, other voltages available on request.
- Tailor-made systems available.

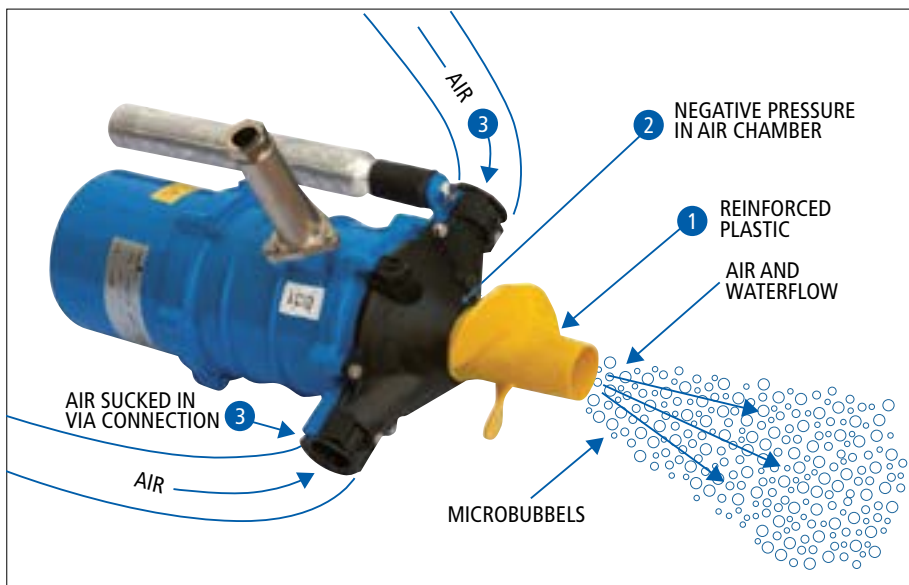

How it works

The propeller (1) moves large amounts of water creating a vacuum in the air chamber (2) and air is sucked in through the connections (3). The propeller pump carries the air bubbles that have been drawn in along with the water current (4).

AirFlow aerators

AirFlow propeller pumps combine the power of movement with injected air in the form of micro-bubbles, which are absorbed in water, necessary for an accelerated biodegradation of organic substances and important for all water life.

Type	Configuration	P2 motor kW	Voltage V/Hz	Capacity		Cable m	L x W x H mm	Art. no.
				m ³ / h	O ₂ /m ³			
AirFlow 37 F	Floating	0.37	230/50	70	15	20	980 x 980 x 770	103162
AirFlow 37 S	Fixed	0.37	230/50	70	15	20	556 x 590 x 530	103151
AirFlow 75 F	Floating	0.75	230/50	80	20	20	980 x 980 x 770	103155
AirFlow 75 S	Fixed	0.75	230/50	80	20	20	556 x 590 x 530	103152
AirFlow 110 F	Floating	1.10	230/50	150	30	20	980 x 980 x 770	103156
AirFlow 110 S	Fixed	1.10	230/50	150	30	20	556 x 590 x 530	103153

AirFlow 75 S



Applications

- Oxygenation.
- Circulation.
- Anti-layer formation.
- Flotation.
- Soil amelioration.
- Aeration.
- Degassing.
- Keeps water free of ice.

Technical information

- Variable flow angle.
- Integrated Venturi system.
- Base plate with counterweight.
- Protective cage around the propeller.
- Inc. anchoring eyelets.
- Also available in 400 V 3 Ph.
- Motor cable can be supplied in the required length.
- 'F' model with plastic float.
- Speed 2800 rpm.

- Control pump, see page 22.
- Anchoring set, see page 23.

AirFlow 110 F



Mega AirFlow aerators

The powerful Mega AirFlow propeller pump provides a very large capacity, combined with oxygen injection and is ideal for use in large water projects.

Type	Configuration	P2 motor kW	Voltage V/Hz	Cable m	L x W x H mm	Art. no.
Mega AirFlow 220 F	Floating	2.2	400/50	20	1000 x 1200 x 1390	103166
Mega AirFlow 300 F	Floating	3.0	400/50	20	1000 x 1200 x 1390	103167

Mega AirFlow 220 F



Applications

- Oxygenation.
- Circulation.
- Anti-layer formation.
- Flotation.
- Aeration.
- Degassing.
- Keeps water free of ice.
- Soil amelioration

Technical information

- Variable flow angle up to 45°.
- Integrated Venturi system.
- Motor cable can be supplied in the required length.
- 'F' model with plastic float.
- Speed 2800 rpm.
- Control pump, see page 22.
- Anchoring set, see page 23.



MegaFlow Combi

Combi-systems, consisting of a MegaFlow mixer and an AirFlow aerator, integrated in a power unit, to provide aeration and circulation for large quantities of water in large-scale water projects.

Type	Configuration	P2 motor kW	Voltage V/Hz	Cable m	L x W x H mm	Art. no.
MegaFlow Combi 75 / AirFlow 110 F	Floating	0.75 + 1.10	230/50	20	1958 x 1860 x 1306	103171
MegaFlow Combi 75 / AirFlow 110 S	Fixed	0.75 + 1.10	230/50	20	1958 x 1006 x 13006	103170
MegaFlow Combi 150 / AirFlow 110 F	Floating	1.5 + 1.10	230/50	20	1958 x 1860 x 1306	103173
MegaFlow Combi 150 / AirFlow 110 S	Fixed	1.5 + 1.10	230/50	20	1958 x 1006 x 13006	103172

MegaFlow Combi / AirFlow



MegaFlow in operation



Applications

- Oxygenation.
- Circulation.
- Anti-layer formation.
- Soil amelioration.
- Aeration.
- Keeps water free of ice.

Technical information

- Variable flow angle.
- Also available in 400 V.
- Motor cable can be supplied in any length.
- Fixed and floating set-up.
- More designs possible.
- 'F' model with plastic float.
- Speed 1400 / 2800 rpm.

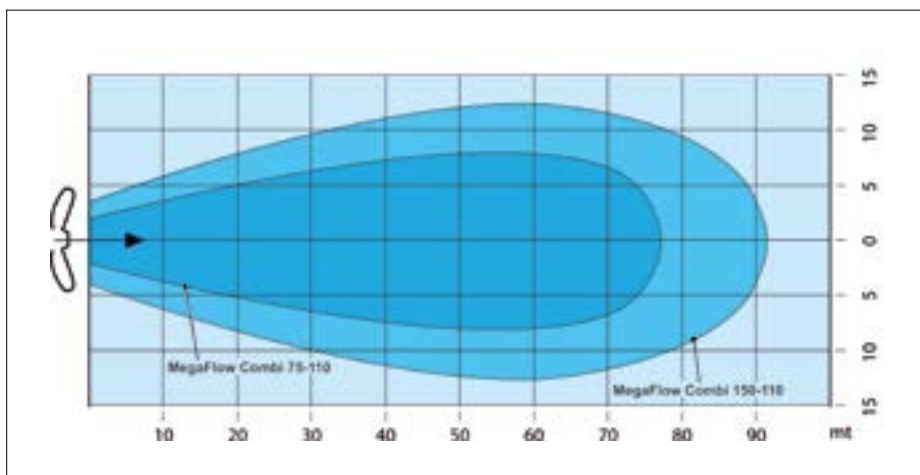

Work area

- Control pump, see page 22.
- Anchoring set, see page 23.



[CLICK
HERE FOR
VIDEO
IMPRESSION](#)

S-Flow volume aerators and V-Flow fountain aerators

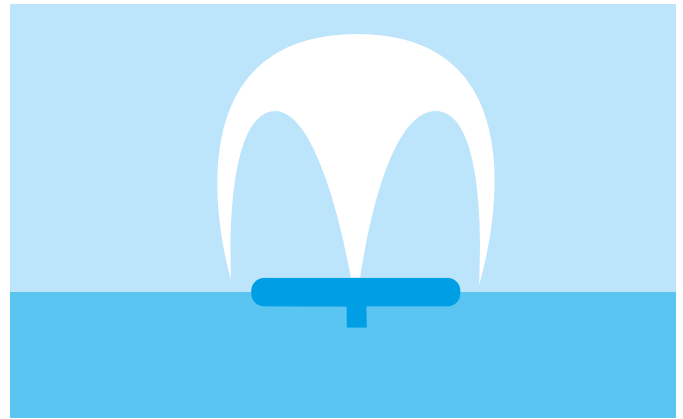
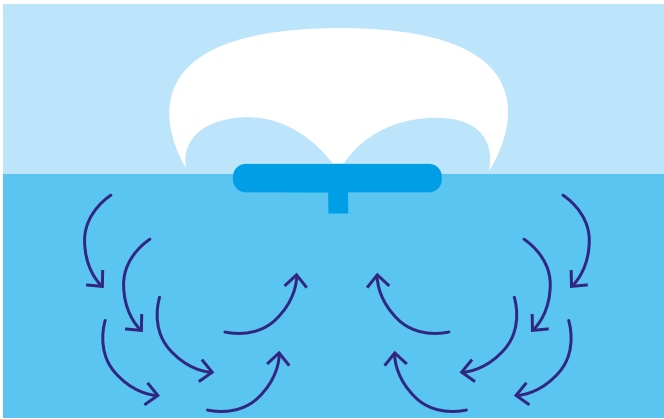

Aeration of fish ponds, public ponds and fish farms

Surface aeration is extremely important in situations where degassing is essential. In many cases, the removal of dangerous gases – which are extremely harmful to fish and the overall water quality – is much more important than simply aerating the water.

S-Flow volume aerators

The surface aerator pumps a large volume of water into the air, releasing ammonia and carbon dioxide, and then releases oxygen back into the water. It creates a thoroughly mixed, aerated zone around the unit, producing a better aquatic environment without stratification.

V-Flow Fountain aerators

Fountain aerators increase the water's oxygen content, thus increasing the volume of the fountain pattern without disturbing the bottom of the pond. As the pumps are highly dirt-resistant, they are particularly suitable for use in public bodies of water. The addition of coloured LED lighting adds to the fun in the evenings.

Technology

The specially designed motors are the powerhouse behind any installation and are built for continuous use under highly variable conditions with a wide variety of applications.

- Oil-immersed double mechanical seal (oil biodegradable).
- Bronze or stainless-steel motor housing.
- Motor cables can be supplied in any length.
- Connection voltage 230 V 1 Ph (up to 1.5 kW), 400 V 3 Ph, other voltages available on request.

S-Flow



V-Flow Pro



V-Flow Economic



S-Flow volume aerators

The enormous water displacement results in a temperature reduction of heated water, degassing and oxygenation.

Type	Configuration	P2 motor kW	Voltage V/Hz	Capacity m ³ / h	Cable m	L x W x H mm	Art. no.
S-Flow 37 F	Floating	0.40	230/50	120	20	680 x 680 x 486	103165
S-Flow 75 F	Floating	0.75	230/50	192	20	680 x 680 x 486	103159
S-Flow 110 F	Floating	1.10	230/50	186	20	680 x 680 x 486	103160
S-Flow 150 F	Floating	1.50	230/50	222	20	680 x 680 x 486	103163
S-Flow 220 F	Floating	2.20	400/50	324	20	680 x 680 x 486	103164

S-Flow top view



S-Flow front view



Applications

- Oxygenation.
- Temperature reduction.
- Aeration.
- Degassing.

Technical information

- Protective cage around the propeller pump.
- Inc. anchoring eyelets.
- Also available in 400 V 3 Ph.
- Motor cable can be supplied in the required length.
- Plastic float.
- Highly resistant to dirt.
- Types 37 and 75: 1400 tpm.
- Types 110, 150 and 220: 2800 tpm.
- Control pump, see page 22.
- Anchoring set, see page 23.



V-Flow Pro Fountain Aerators

Fountain aerators are multi-functional; the voluminous fountain sculpture is a beautiful eye-catcher in garden and park ponds and also increases the oxygen content of the water. By reducing the temperature of warming surface water, algae formation is controlled and water quality increased.

The open propeller impeller makes the fountain aerators highly dirt-resistant and particularly suitable in natural ponds, canals and open water.



Type	Configuration	P2 motor kW	Voltage V/Hz	Fountain form			Cable	Diam. x height mm	Art. no.
				ø m	H max m	m ³ / hour			
V-Flow Pro 60 F	Floating	0.60	230/50	5.50	1.30	60	20	980 x 770	103168
V-Flow Pro 60 F	Floating	0.60	400/50	5.50	1.30	70	20	980 x 770	103176
V-Flow Pro 75 F	Floating	0.75	230/50	6.50	1.70	60	20	980 x 770	103157
V-Flow Pro 75 F	Floating	0.75	400/50	6.50	1.70	60	20	980 x 770	103169
V-Flow Pro 110 F	Floating	1.10	230/50	7.00	1.90	90	20	980 x 770	103158
V-Flow Pro 110 F	Floating	1.10	400/50	7.00	1.90	90	20	980 x 770	103175



Floodlights selection table (optional)				
Type	Number per set	Power consumption	Light source	Art. no.
LSX 18-3 WW	3	3 x 18 W	LED warm white 3000 K	104042
LSX 24-3 RGBW	3	3 x 24 W	LED RGBW	104043

Visibility	● ● ● ● ●
Wind resistance	● ● ● ● ●
Noise level	● ● ● ● ●

- Control pump and floodlights, see page 22.
- Anchoring set, see page 23.

V-Flow Pro Fountain Aerators

Powerful fountain aerator equipped with highly efficient and energy-efficient PM motor. Fully adjustable in capacity/fountain height and power consumption. These installations are used in large ponds to improve water quality and as a large, decorative fountain.

Type	Configuration	P2 motor kW	Voltage V/Hz	Fountain form			Cable	Diam. x height mm	Art. no.
				ø m	H max m	m ³ / hour			
V-Flow Pro 220F	Floating	0 -2.20	230/50	0 > 7.50	0 > 3.50	0 > 200	20	980 x 770	103174
V-Flow Pro 220 F	Floating	0 -2.20	400/50	0 > 7.50	0 > 3.50	0 > 200	20	980 x 770	103177

V-Flow Pro 220 F



V-Flow Pro 220 F



Technical data

Applications

- Decorative fountain for large ponds.
- Aeration.
- Oxygenation.
- Temperature reduction surface water.
- Algae control.

Technical information V-Flow Pro 220 F

- Industrial high-efficiency PM motor, suitable for continuous operation.
- Motor housing made entirely of bronze, brackish water resistant.
- Propeller impeller, highly dirt-resistant.
- Large protective basket as protection against large components (wood, plastic, etc.) and protection for fish.
- Flat, inconspicuous float.
- Delivery includes frequency converter for manual adjustment of fountain height capacity.

Technical information AC drive

- Version IP 20 for installation in a main control cabinet.
- Version IP 65 for outdoor installation, without further pump/light control.

The V-Flow Pro 220 F is equipped with a PM motor (permanent DC motor). The motor is controlled by the frequency controller supplied, this allows the motor speed - and fountain height - to be changed as required.

Frequency inverter IP 65



Floodlights selection table (optional)

Type	Number per set	Power consumption	Light source	Art. no.
LSX 18-3 WW	3	3 x 18 W	LED warm white 3000 K	104042
LSX 24-3 RGBW	3	3 x 24 W	LED RGBW	104043

Visibility	● ● ● ● ●
Wind resistance	● ● ● ● ●
Noise level	● ● ● ● ●

- Control pump and floodlights, see page 22.
- Anchoring set, see page 23.

V-Flow Economic Fountain aerators

The motor technology is similar to the Pro series - in this series there is no large protective basket, the square float is more visible on the surface of the water.

Type	Configura-tion	P2 motor kW	Voltage V/Hz	Fountain form			Cable	Diam. x height mm	Art. no.
				ø m	H max m	m ³ / hour			
V-Flow 37 FE	Floating	0.37	230/50	4.00	1.20	50	20	680 x 486	103192
V-Flow 60 FE	Floating	0.60	230/50	5.50	1.30	60	20	680 x 486	103193
V-Flow 75 FE	Floating	0.75	230/50	6.50	1.70	60	20	680 x 486	103190
V-Flow 110 FE	Floating	1.10	230/50	7.00	1.90	90	20	680 x 486	103191

V-Flow Economic



V-Flow Economic top view



No floodlights are applicable in the Economic version.

Visibility	● ● ● ● ●
Wind resistance	● ● ● ● ●
Noise level	● ● ● ● ●

- Control pump, see page 22.
- Anchoring set, see page 23.



[CLICK
HERE FOR
VIDEO
IMPRESSION](#)

Scope of delivery and expansion options

Control units for pumps		
Description/function	Pump	Pump
Design	230 V	400 V
Pump		
20 m power cable for pump ¹	✓	✓
Pump control 230 V		
Capacitor box with on/off operating switch (except AT15/AT30/AT35)	✓	–
Extension options pump control 230 V		
Digital timer for pump	Optional	–
Frequency converter for adjustment capacity/fountain height	Optional	–
Working switch pump on 0 timer	Optional	–
Basic control pump 400 V		
Control box with motor protection and working switch on off	–	Optional
Expansion options for pump control 400 V		
Digital timer for pump	–	Optional
Working switch pump on 0 timer	–	Optional
Frequency converter for adjustment capacity/fountain height	–	Optional

✓ = *) Included in delivery.

¹ = Extension of power cable possible.

Controls for pump and lighting are merged in one control box.

Controllers for LED lighting		
LED lighting	Warm/White	RGBW
20 m power cable for light ²	✓	✓
Basic control LED lighting set, Primary 230 V or 400 V, secondary 24 V DC		
230 V: Transformer 230/24 V 400 V: The supply cable must have a 0 line (3 Ph-0-A) if present, control is adjusted accordingly	✓	✓
Remote control (Remote control)	Optional	✓ ¹
Dimming LED lighting	Optional	✓ ¹
Colour choice and colour change RGBW programme	–	✓ ¹
Touchscreen RGBW (in control box)	–	Optional
Selection table extension timers for lighting		
Digital timer for lighting	Optional	Optional
Timer with light sensor (on cabinet or external, with 5-metre cable)	Optional	Optional
Digital Astro time clock (switches on at sunset)	Optional	Optional
Working switch for lighting on 0 timer	Optional	Optional
If a timer is chosen for pump and lighting, we build in 1 combination timer.		
Basic control unit	Pump	Pump + lighting
Plastic, anthracite or grey, splash-proof, wall-mounted	✓	✓
Choice of control unit version		
Lockable with lock	Optional	Optional
Steel housing, splashproof	Optional	Optional

✓ = *) Included in delivery.

¹ = Remote control up to max 20 m, without obstacles.

² = Extension of power cable possible.

Controls for pump and lighting are merged in one control box.

Shore and bottom anchoring for floating pump sets

Bank anchor kit



Bank anchoring



Type	Stainless steel cable length m	Material ground pins	Length of ground pins mm	Art. no.
FS 304 - 30	30	Stainless steel 304	500	902591

Ground anchor for floating pump sets

Ground anchor set



Ground anchor

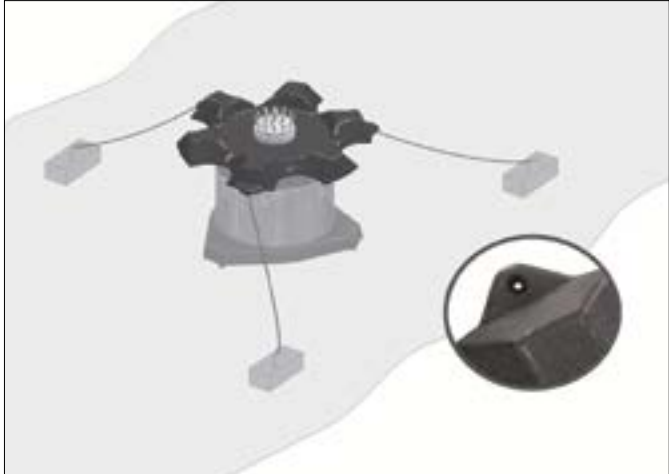

Type	Stainless steel cable length m	Feet	Art. no.
Anchoring set FS BP-30	30	Plastic/concrete	902593

Anchoring example Mega installations

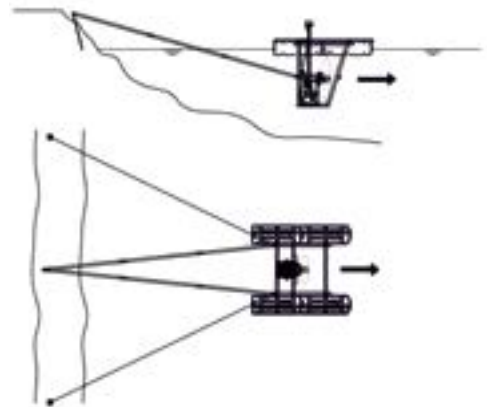
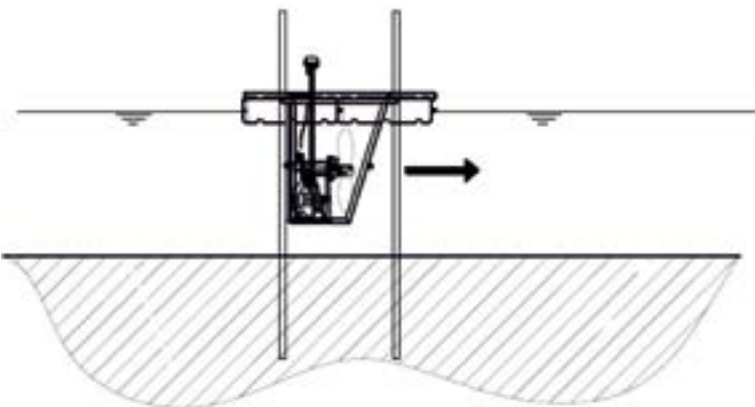

AirTec air membrane pumps

Oxygen enrichment makes a significant contribution to the well-being of fish and plants in private ponds and to the bacterial culture in filter systems that convert organic substances. Also suitable for keeping water free of ice in ponds.

Type	Motor W	Voltage V/Hz	Motor cable m	Qmax l/h	Hmax m	Number stones	Hose m	L x W x H mm	Art. no.
AirTec Set 600	10	230/50	2	600	2	2	2 x 5	140 x 105 x 115	01C015
AirTec Set 1200	15	230/50	2	1200	2	2	2 x 5	180 x 145 x 145	01C012
AirTec Set 2400	30	230/50	2	2400	3	4	4 x 5	216 x 170 x 175	01C013

AirTec



Applications

- Oxygenation.
- Aeration.
- Degassing.

Technical information

- Suitable for outdoor set-up.
- Very low noise level when operational.
- Complete set with hose, divider and air stones.
- Plastic housing.

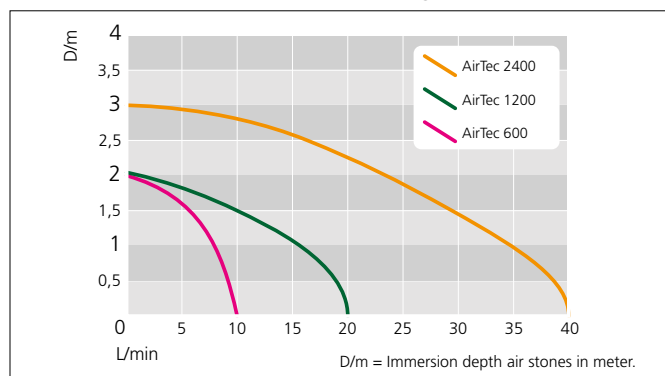

AirTec Pro Air membrane pumps

Extremely robust air membrane pumps with aluminium housing to supply oxygen in larger ponds, fish containers and filter systems.

Type	Motor W	Voltage V/Hz	Motor cable m	Q max l/h	max m	Pump connection \varnothing mm	Divider \varnothing 19 mm		L x W x H mm	Art. no.
							\varnothing hose conn.	Number		
AirTec Pro 3600	40	230/50	1.5	3600	3	19	4	4	270 x 200 x 200	103016
AirTec Pro 4800	50	230/50	1.5	4800	3.5	19	4	6	270 x 200 x 200	103018
AirTec Pro 6000	60	230/50	1.5	6000	3.5	19	4	6	270 x 200 x 200	103021

AirTec Pro



Applications

- Oxygenation.
- Aeration.
- Degassing.

Technical information

- Suitable for outdoor set-up.
- Very low noise level when operational.
- Including divider.
- Aluminium housing.

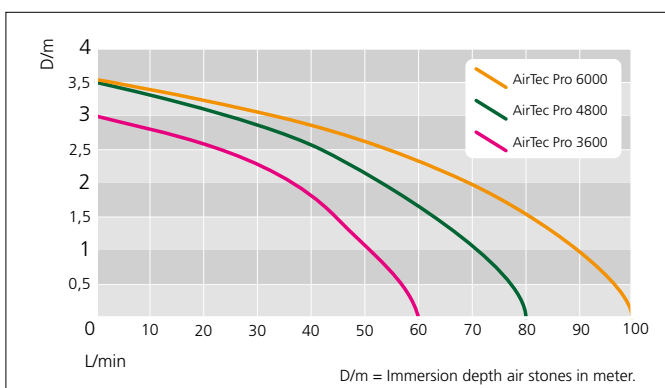



HI-OXY air stones, balls and discs

High quality grey/blue air stones, the special production process results in many extra pores that provide an airflow with fine air bubbles.

Type	Dimensions ø cm	Capacity l/h	Connection ø mm	Art. no.
HI-Oxy ball	5	120	8/4	903005



Type	Dimensions ø x L cm	Capacity l/h	Connection ø mm	Art. no.
HI-Oxy cylinder	3 x 13	240	8/4	903007
HI-Oxy cylinder	5 x 20	1000	8/4	903008



Type	Dimensions ø cm	Capacity l/h	Connection ø mm	Art. no.
HI-Oxy disc	10.7	250	8/4	903009
HI-Oxy disc	20	1500	9	903010



Type	Dimensions l x ø cm	Capacity max. l/h	Connection ø mm	Art. no.
Stainless steel AirTube	24 x 3	2500	6	903015



NITTO piston air pumps

NITTO piston pumps are proven for their high quality and quiet operation. The piston system offers a higher efficiency and longer service life as compared to diaphragm air pumps.

Type	Motor W	Voltage v/Hz	Optimum operating point		Connection mm	Dimensions L x W x H mm	IP	Art. no.
			l/h	H/m				
LA-60 B*	64	230/50	3600	1.5	18	305 x 214 x 188	54	103030
LA-800 B*	86	230/50	4800	1.5	18	305 x 214 x 188	54	103031
LA-100 A	100	230/50	6400	1.8	26	407 x 210 x 232	55	103032
LA-120 A	130	230/50	7800	1.8	26	407 x 210 x 232	55	103033

* B series has a better performance curve with higher maximum working pressure as compared to the E (Economic) models in the NITTO range.



Staying in the range of the optimum operating point lengthens the service life. Higher back pressures resulting from long or smaller-diameter pipes or hoses can increase piston wear. For this reason, fitting a pressure gauge on the outlet side is recommended.



AUGA 2024

Further developments and technical changes without notice.

Typesetting and printing errors do not constitute grounds for compensation. Full or partial reproduction of this publication in any shape or form is prohibited without the prior written consent of AUGA.

AUGA® is a registered trademark.



Winkelskamp 13
7255 PZ Hengelo (Gelderland)
The Netherlands
Tel.: +31 (0) 575 46 80 20
info@auga.nl
www.auga.nl

